



# FRONT RANGE WOODTURNERS

July, 2008, Volume 8 - Number 07

## Inside this Issue

<b>Upcoming Events</b> .....	1
<b>News</b> .....	1
Group Purchases and Individual Catalog Orders .....	1
New Club Bylaws/Executive Committee Meeting.....	1
Rocky Mountain Turning Symposium.....	1
Club Library .....	2
Ongoing Content.....	2
Upcoming Symposiums .....	2
Featured Providers .....	2
<b>Show and Tell</b> .....	2
<b>Demonstration</b> .....	4
Demonstration Part Deux .....	6
<b>Rockler</b> .....	7
<b>Web Stuff</b> .....	7
<b>Classifieds</b> .....	7
<b>Club Information</b> .....	7
General Meeting Information .	7

## Upcoming Events

**Important Note:** Even though a turning challenge is announced for a meeting, this does not mean that other items can't be brought for the show & tell. Feel free to bring in what you've created and don't feel you have to be a master turner to show off your work. Everyone has start as a novice.

July – Tuesday, July 1. Dick Brecken will be demonstrating turned kaleidoscopes. Turning Challenge: Spheres or Soren-style Scoops.

August – Tuesday, August 5. Dick Moody will be demonstrating "Photographing Your Work."❖

## News

### Group Purchases and Individual Catalog Orders

Following is a message from our Group Buy Chairperson, Roger Holmes:

Please see the FRW website or the Club Info binder for the Group Purchases and Individual Catalog Orders rules. Copies are also available at the Group Purchase table before meetings. Please make checks payable to Roger Holmes for Craft Supplies and Woodcarvers Supply group purchases. Make checks for CA Glue and Sanding Disks payable to Del Fussell. To participate in Individual Catalog Orders, sign up on the sheets that are passed around at each meeting.

### Group Buy Schedule for 2008:

Group purchase orders will be taken at the monthly meetings in **January, April, July and October.**

### Group Buy Coordinator Contact Information:

Roger Holmes – 1844 W. Plum Cir., Louisville, CO 80027 - 303-665-8041 - [roger\\_holmes@comcast.net](mailto:roger_holmes@comcast.net)

Del Fussell – 11455 N. Antelope Ln., Parker, CO 80138 - 303-805-2663 - [fussell6@comcast.net](mailto:fussell6@comcast.net)

**Note:** If Rockler stocks an item, please purchase that item from Rockler at their 10% club discount.

We owe that to Rockler for being a wonderful host to our club.

### New Club Bylaws/Executive Committee Meeting

The next meeting is to be announced once we can get everyone's schedules coordinated.

Just a reminder to bring your suggestions and comments to the next Executive Committee Meeting, or send them to Andy, Bear, or Alisa.

We are still planning to discuss the suggested edits to the bylaws. We hope to get final input at this meeting so that we can present the bylaws for review and approval by the general membership. So, if you have any suggestions or questions for the bylaws, please attend the announced meeting.

You can see the proposed bylaws at the direct link below:

[http://www.frontrangewoodturners.org/FRW\\_BylawsProposed20080329.pdf](http://www.frontrangewoodturners.org/FRW_BylawsProposed20080329.pdf)

### Rocky Mountain Turning Symposium

The RMW Symposium has suggested giving a demo room to each local chapter. Correction: The idea is that each chapter can then help with the technical support for the demos in the room (running cameras, cleaning up, etc.). This will assist RMW in putting on the symposium, which is the only woodturning symposium being held in Colorado. If you are

# FRONT RANGE WOODTURNERS

interested, contact Andy at the May meeting.

## Club Library

See the website or the *Club Info* binder for the library rules. Following is a summary of information from our Librarian, Dave Hawley:

Please be sure to sign out items – as busy as we all are in working to assist members to rapidly sign out Library items, sometimes we slip, so we need your help.

Please note that **all items borrowed from the Library should be returned on or before the next meeting.** Please use the drop box, or otherwise get items to a Librarian, before the next meeting if you cannot attend. With prior arrangement, and based on prior coordination with a Librarian at a meeting (to avoid being on the Rogues List), a two-month loan is possible for items that are not just released and extremely popular.

Please continue to open and/or download the on-line PDF Library Inventory listings, make the print larger, and word search for items that interest you, and then build your "wish list" for the next meeting.

Please continue to contribute UNCONTROLLED ("Red Dot") items – it's a fun way of sharing.

Thanks again to Earl Waibel, Richard Kuivila, Bob Britt, and Bob Olsen for their wonderful help during the meetings! Please take time to thank them for their hard work!

## Ongoing Content

To streamline the newsletter, we've moved the content that was in the middle of the newsletter, but never changed. Please go to the website at [www.frontrangewoodturning.org](http://www.frontrangewoodturning.org) or ask the librarian, Dave Hawley, for

the Club Info binder at the next meeting. We'll keep updating it with reference information as we receive it, such as the group buy requirements, library rules, etc.

## Upcoming Symposiums

### 10<sup>th</sup> Annual Rocky Mountain Woodturning Symposium

Sept 13th - 14th, 2008 at The Ranch / Larimer County Fair Grounds in Loveland, Colorado. Contact Allen Jensen at 970-663-1868 or at [rajconst@aol.com](mailto:rajconst@aol.com). Check out their website at <http://www.rmwoodturningsymposium.com/> for more information. This is one of the few local symposiums, so we should support them.

## Featured Providers

**Rocklers**, Colorado Blvd, Denver, provides a 10% discount for club members – see the Rockler section on page 7. Rockler will be keeping the cash register open until the end of the meeting break. Try to do your shopping before the end of the break, so that they can get out quickly after the end of the meeting.

**Wood Emporium**, Loveland, provides a 10% discount for FRW members.

Craft Supplies offers monthly deals with special discount codes that expire monthly. Discounts and codes will be posted on the FRW website. ❖

## Show and Tell

The turning challenge for the June meeting was Nested Bowls.



Steve Claycomb – Bowl of cottonwood crotch burl with mineral oil finish.



Tom Tedesco – Square-edged lidded bowl of oak and maple.



Steve Claycomb – Winged hollow form of natural-edged, honey locust crotch burl. Finish is acrylic over lacquer.



Bruce Perry (aka the Silver Smudge) – Hollow forms of birch. Both from same branch, with one

# FRONT RANGE WOODTURNERS

oriented with end grain, and one oriented with cross grain.



Steve Claycomb – Egg-shaped basket with carved handle of honey locust. Finish is acrylic over lacquer.



Steve DeJong – Vase of beetle-killed pine.



Pete Holtus – Hollow form with textured surface.



Grover Brown – Nested bowls of walnut burl. Winner of the Turning Challenge.



Pete Holtus – Bowl of Norfolk pine, side and top views.



Pete Holtus – Hollow form with carved rim of ambrosia maple.



Pete Holtus – Lidded box with carved lid and finial.



Dave Moncada – Lidded box of “Rockler coyote.”



Dave Moncada – Lidded box with finial of “Rockler coyote.”



Less Stern – Small lidded box of acrylic. Suggests using knife

# FRONT RANGE WOODTURNERS

blanks for large, colorful acrylic blanks.

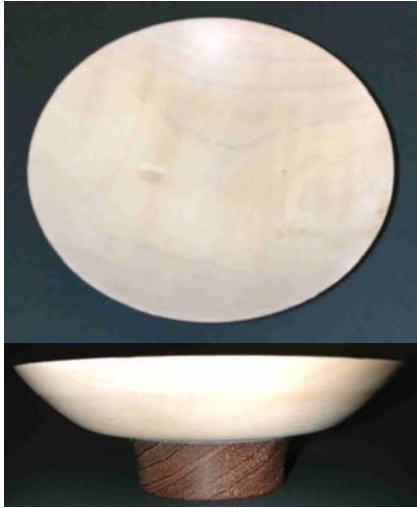

Bill Norberg – Plate with foot of maple and “unknown” wood (wenge?), top and side view.



Jerry Smith – Segmented vase of walnut, cherry, maple, and oak with sanding sealer finish. ❖

## Demonstration

Soren Berger demonstrated how to turn a sphere using his new Circle Calipers, and then turned one of his signature globular scoops.

diameter of the blank to create the proportional marks for subsequent angles.



He is now cutting a straight angle between the line on the cylinder and the line on the face. Basically, he's cutting the “square” of the cube into an octagon (as seen from the side).



Earl Waibel – Laminated pen of maple, bloodwood, veneer, brass, and “lots of swear words.” It's still gorgeous, Earl.



He's cutting the faces down to just spigots, making sure to leave a blank that is a true cube with equal length sides.



Cutting the angle on the headstock side.



Dave Moncada – Lidded box of ivorywood.



Using his Circle Calipers, he's laid out the lines for taking off the first set of corners. The lines are marked on the cylinder and both faces. His Circle Calipers use the

# FRONT RANGE WOODTURNERS



Using his Caliper (see on headstock), Soren marked the next set of lines delineating the angles to be cut. He cuts a straight line between the marked lines, making the "octagon" seen from the side into a sixteen-sided shape with even sides.

By continuing to cut off the corners, eventually he will end up with a sphere. (4-sided to 8-sided to 16-sided to 32-sided to sphere).



Soren himself turning a sphere. He's laid out the lines by marking the remaining high points (so he

knows what to remove). He has "eyeballed" marking the center lines between the high points to help guide him in cutting the angles to make a 32-sided shape. The last step is to smooth any bumps into a true sphere.

He suggests using a ring of metal to make sure that there are no high or low spots. A true circle will fit snugly against the surface of the sphere.

Be sure to set a true tangent on the final cuts parting off the sphere to make sure you don't end up with points.



Now turning the sphere for one of his scoops. He has also shaped the handle.



He has mounted the handle on an eccentric axis and turned another detail. He is finishing the outside of the scoop.

Once he has finished the outside of the scoop and handle, he will hollow out the scoop. He uses a special ring chuck with a small, sharp dovetail rim mounted in jawed chuck that grips the round surface of the scoop. He must be gentle during the hollowing, but it holds rather well. He then sands off any marks made by the rim.

# FRONT RANGE WOODTURNERS

## Demonstration Part Deux

Just for "fun," Richard Kuivila worked out the math that was required to determine these angles for each set of cuts. See the following for his diagrams, in case you're curious. (Thanks, Richard!)

Math for Soren Berger Sphere layout technique

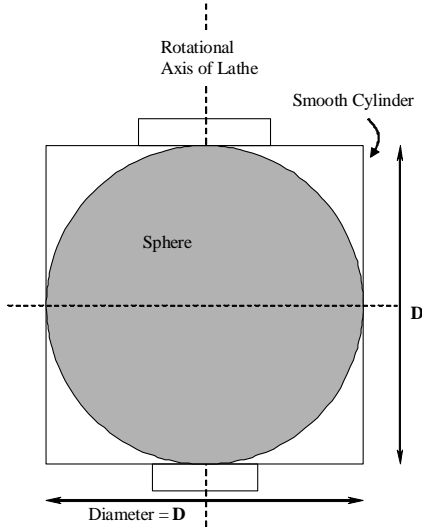

D = Diameter of Sphere  
(and length of smooth cylinder)  
 $X_1 = .293 \times D$   
 $X_2 = .104 \times D$

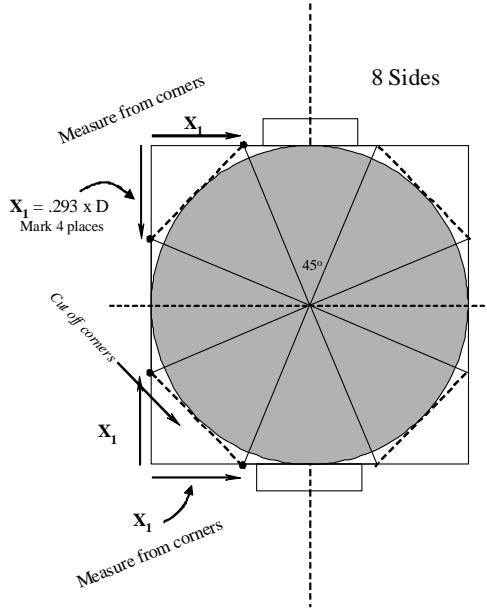

Math for Soren Berger Sphere layout technique

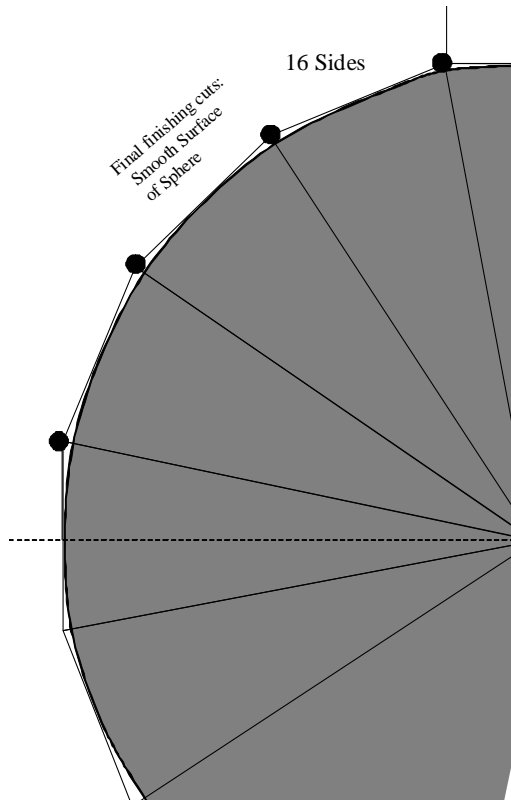
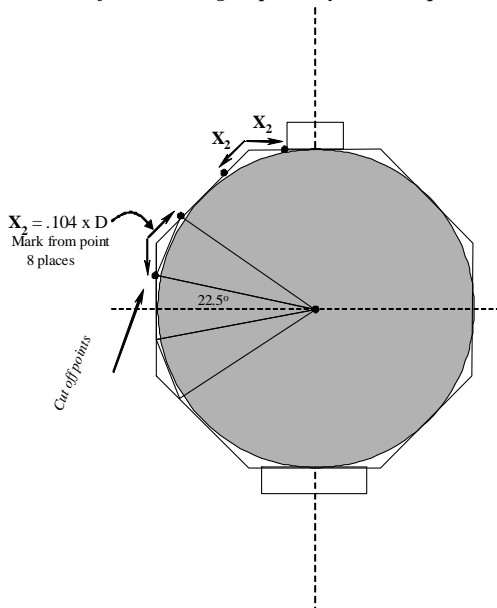

# FRONT RANGE WOODTURNERS



## Rockler

Patronizing their store is the best "thank you" we can give Rockler for their generosity in letting us use their facilities for our ever-growing membership. Keep in mind that they keep the register open late on meeting nights just for us. Just be sure to complete any purchases no later than the mid-meeting break so these poor guys can start shutting down and go home.

As always – all FRW members get 10% off all items, except electrical or sale items, all the time. Just present your FRW membership card at time of purchase. (Note: This offer is only good at the Denver retail location, and is not valid for any other location or for Internet purchases.)

If you have suggestions for tools or materials that Rockler can carry, contact Rich Johnson, manager of the Denver store. Rockler web site: [www.rockler.com](http://www.rockler.com).

## Web Stuff

The Front Range WoodTurners Web site address (*new*):

[www.frontrangewoodturners.org](http://www.frontrangewoodturners.org)

You can contact our webmaster, Jason Springfield, at [Jason\\_springfield@yahoo.com](mailto:Jason_springfield@yahoo.com) for suggestions about content.

Get the latest information about upcoming events, meetings, and view the excellent photos of the show and tell gallery.

Other sites of interest:

(Rky Mtn Woodturners, Ft Collins)  
[www.verinet.com/~drmeli/rmw.html](http://www.verinet.com/~drmeli/rmw.html)  
[www.lathes.co.uk](http://www.lathes.co.uk)  
[www.woodworkingbasics.com](http://www.woodworkingbasics.com)  
[www.treelineusa.com](http://www.treelineusa.com)  
[www.woodturnerscatalog.com](http://www.woodturnerscatalog.com)  
[www.kestrelcreek.com](http://www.kestrelcreek.com)  
[www.choicewoods.com](http://www.choicewoods.com)  
[www.woodturner.com](http://www.woodturner.com)

[www.woodturningonline.com](http://www.woodturningonline.com)  
[www.kazistudio.com](http://www.kazistudio.com) ❖

## Classifieds

*Please note:* All advertising in the Classifieds is free, but please be sure to notify the newsletter editor if an item is no longer for sale.

*Ad Policy* – All ads that are older than 3 months will be deleted, unless you contact the newsletter editor.

**For Sale** - Vicmarc VL300 Longbed Lathe. 3HP. Includes Vicmarc 5 1/2" Chuck. Originally paid \$5,000 for lathe and accessories, asking \$3,000. Contact Brandon at 303.507.5206. More info: [brandonmackie.com](http://brandonmackie.com).

**For Sale** - Like new, complete, Tormek sharpening system for sale. Includes all of the original manuals, adaptors, jigs. Like new. Want \$400. Also, little used 20" RBI scroll saw for sale. Includes operation manual, mobile stand with locking wheels, magnifier with light, many scroll saw patterns, 3 scroll saw books, at least 100 extra blades, etc. New price was \$1100+. Asking \$550. Contact Rick Orr at mobile 303-570-5298. Leave a message if I can't pick up.

**For Sale:** Nova Cole Jaws for Teknatool chucks. Holds bowls up to 10" diameter. Brand new, plastic bag of screws and instruction books never opened. Cost new \$84.99 asking \$65.00. I bought wrong size. Call Ron Wentz at 303-989-3966 or catch me at FRW meeting. [Ronwentz@aol.com](mailto:Ronwentz@aol.com) ❖

## Club Information

*President/Videographer:*

Andy Zartman  
phone: 303-859-0724  
email: [AWZartman@gmail.com](mailto:AWZartman@gmail.com)

*Vice-President/Program Director:*

Bear Limvere  
phone: 303-648-3414  
e-mail: [Bear@BearLimvere.com](mailto: Bear@BearLimvere.com)

*Treasurer:* Ron Ainge

phone: 720-747-4852  
email: [clu1.2@netzero.net](mailto:clu1.2@netzero.net)

*Secretary/Newsletter*

*Editor/Membership Chair:* Alisa Limvere

phone: 303-648-3414  
e-mail: [alisalimvere@yahoo.com](mailto: alisalimvere@yahoo.com)  
*Assistant Newsletter Editor:*

Ken Miller

phone: 303-947-3049  
e-mail: [kmiller@figgbridge.com](mailto: kmiller@figgbridge.com)

Deadline for submitting material for inclusion in the newsletter is 15 days before the next meeting.

*Publicity/Shop Tour Chair:*

Marty Christensen

phone: 303-252-7776  
e-mail: [mecstoys@msn.com](mailto: mecstoys@msn.com)

*Librarian:* Dave Hawley

phone: 303-443-2332  
e-mail: [dave\\_hawley@comcast.net](mailto: dave_hawley@comcast.net)

*Raffle-Wood Director:* Lavonne Kaiser  
phone: 303-791-6206

*Group Buy Coordinators:* Roger Holmes

phone: 303-665-8041,  
[roger\\_holmes@comcast.net](mailto: roger_holmes@comcast.net).

*Mentoring Program Chair:* Steve

DeJong, phone: 303-829-0246  
e-mail: [stevejdejong@hotmail.com](mailto: stevejdejong@hotmail.com)

*Internet Chairman:* Jason Springfield  
phone: 720-283-4000

email: [Jason\\_springfield@yahoo.com](mailto: Jason_springfield@yahoo.com).

*Coffee Coordinator:* Randy Weems

phone: 303-797-3215  
e-mail: [rweems2032@aol.com](mailto: rweems2032@aol.com)

## General Meeting Information

Normal meetings are the first Tuesday of every month, unless otherwise rescheduled.

Meeting place is at Rockler Woodworking & Hardware, 2553 So. Colorado Blvd. #108 Denver, CO (west side of Colorado Blvd. opposite the mall).

Meetings are 6:30 PM – 9:00 PM.

# FRONT RANGE WOODTURNERS

---



# FRONT RANGE WOODTURNERS

July, 2008, Volume 8 - Number 07

---

Front Range WoodTurners  
P.O. Box 714  
Franktown, CO 80116